

AIR ULTRASONIC CERAMIC TRANSDUCERS

Open, Enclosed, Pulse Transit, Wide Bandwidth and Built-in Crystal Oscillator Types

Ultrasonic Ceramic Transducers transfer acoustical energy to mechanical energy or vice versa

The **Standard Open Type Transducer** is constructed in a manner which incorporates the fundamental structure of a piezoelectric ceramic element of the monomorph type with a conical metal resonator. This special combination provides high sensitivity (over -65dB/V/ μ Bar), wider bandwidth, excellent temperature and humidity durability, stable electrical and mechanical characteristics, and small size.

The **Standard Enclosed Type Transducer** can be used for outdoor installation, or, because of its special dust-proof construction, can be used in a dusty atmosphere. The unit has a vibrating diaphragm, consisting of one piezoelectric ceramic element inside a metal case. The back of the transducer is completely sealed with resin. It cannot be used under water, although it is complete enclosed.

The **Pulse Transit Type Transducer** has been developed for pulse-echo type applications. A built-in damper increases internal mechanical resistance of piezoelectric bender to have a greater temporal absorption coefficient and, on the other hand, to have a smaller relaxation time (decay time).

The **Wide Bandwidth Type Transducer** utilizes the resonance of a piezoelectric bender and the resonant effect of a special design cone. This provides a wide zone of operation and is suitable not only as a multi-function remote control device, but also as an intrusion alarm system or for any other application which requires a wide operating frequency range capable of transmitting and receiving many signal frequencies.

The **Built-in Oscillator Type Transmitter** can be directly driven by the DC voltage starting from DC 2 Volts to DC 7 Volts. A custom driving chip and a 30ppm tuning fork type quartz crystal are built-in with open and enclosed type transmitters to ensure a precise frequency and uniform sound pressure output. Continual sound output or pulsing sound output is available upon request.

Applications:

- Remote control devices
- Liquid & bulk Sensors
- Proximity Sensors
- Level controls
- Intrusion alarms
- Motion detectors
- Auto doors
- Counting devices

Open (S) Type Transducers:

Electrical & Mechanical Specifications and Model Numbers:

Model Number Code Standard Type (Open)
 4 0 0 S T 1 6 0
 1 2 3 4 5

Remarks:

1. Center Frequency in **10 2 Hz**
2. Types: S: Open Type; E: Enclosed Type
C: Oscillator Built-in (DC) Type
3. Applications: T: Transmitter, R: Receiver
P: Pulse Transit, W: Wide Bandwidth
4. Gase Dimensions: in mm.
- 5; Remarks: P: Piastic Housing, B: Black Housing

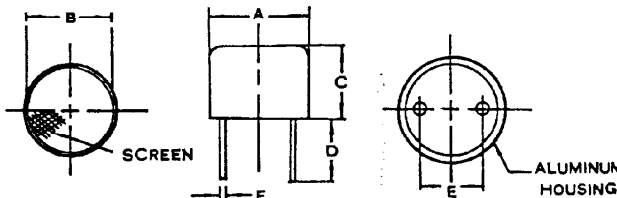

Dimensions - Open Type

Dimensions are in mm, () are in inch

Model Number	A	B	C	D	E	F
250ST(R)160	16.2(.64)	13.0(.51)	12.0(.47)	10.0(.39)	10.0(.39)	1.0(.039)
250ST(R)180	18.2(.72)	15.0(.59)	14.2(.56)	10.0(.39)	11.8(.46)	1.2(.047)
250ST(R)240	24.0(.94)	18.8(.74)	13.5(.53)	10.0(.39)	11.8(.46)	1.2(.047)
328ST(R)160	16.2(.64)	13.0(.51)	9.6(.38)	10.0(.39)	10.0(.39)	1.0(.039)
328ST(R)180	18.2(.72)	15.0(.51)	14.2(.56)	10.0(.39)	11.8(.46)	1.2(.047)
328ST(R)240	24.0(.94)	18.8(.74)	13.5(.53)	10.0(.39)	11.8(.46)	1.2(.047)
400ST(R)10P	9.7(.38)	7.7(.30)	6.7(.26)	9.4(.37)	5.0(.20)	0.5(.020)
400ST(R)120	12.7(.50)	10.0(.39)	10.0(.39)	10.0(.39)	8.4(.33)	1.0(.039)
400ST(R)160	16.2(.64)	13.0(.51)	12.0(.47)	10.0(.39)	10.0(.39)	1.0(.039)
400ST(R)16P	16.2(.64)	13.0(.51)	12.0(.47)	10.0(.39)	10.0(.39)	1.0(.039)
400ST(R)180	18.2(.72)	15.0(.59)	14.2(.56)	10.0(.39)	11.8(.46)	1.2(.047)
400ST(R)240	24.0(.94)	13.8(.54)	14.2(.56)	10.0(.39)	11.8(.46)	1.2(.047)

Tolerance : ± 0.5 (.020")



Electrical Specifications - Open Type



Model Number	Center Frequency (KHz)	Sensitivity or Sound Pressure Level (min.)	Band Width (min.) (KHz)	Capacitance at 1KHz (pF)	Max. Input Voltage (V rms)
250S	T160	112dB at 25.0KHz	2.5KHz/106dB	2500 ± 20%	20
	R160	-67dB at 25.0KHz	2.5KHz/-73dB		
	T180	115dB at 25.0KHz	2.5KHz/109dB		
	R180	-63dB at 25.0KHz	3.0KHz/-70dB		
	T240	117dB at 25.0KHz	2.5KHz/110dB		
	R240	-60dB at 25.0KHz	3.0KHz/-69dB		
328S	T160	115dB at 32.768KHz	3.0KHz/109dB	2000 ± 20%	10
	R160	-67dB at 32.768KHz	3.0KHz/-73dB		
	T180	117dB at 32.768KHz	3.0KHz/110dB		
	R180	-64dB at 32.768KHz	2.5KHz/-70dB		
	T240	117dB at 32.768KHz	3.0KHz/110dB		
	R240	-64dB at 32.768KHz	2.5KHz/-70dB		
400S	T100	110dB at 40.0KHz	4.0KHz/104dB	2000 ± 20%	10
	R100	-70dB at 40.0KHz	3.5KHz/-76dB		
	T120	112dB at 40.0KHz	4.0KHz/106dB	2500 ± 20%	20
	R120	-67dB at 40.0KHz	2.0KHz/-73dB		
	T160/P	119dB at 40.0KHz	4.0KHz/113dB		
	R160/P	-65dB at 40KHz	3.5KHz/-71dB		
	T180	119dB at 40.0KHz	4.0KHz/113dB		
	R180	-65dB at 40.0KHz	3.5KHz/-71dB		
	T240	119dB at 40.0KHz	4.0KHz/113dB		
	R240	-65dB at 40.0KHz	3.5KHz/-71dB		





Sound Pressure Level: 0dB = 0.0002μbar, Sensitivity: 0dB re 1V/μbar
 Operating Temperature: -20°C - + 60°C

Open (S) Type Transducers

Performance Characteristics

250ST(R)160  T
 250ST(R)180  R
 250ST(R)240  R

328ST(R)160  T
 328ST(R)180  R
 328ST(R)240  R

400ST(R)100  T
 400ST(R)120  R
 400ST(R)160(P)  R
 400ST(R)180  R
 400ST(R)240  R

Frequency Characteristics

Receiver: Sensitivity

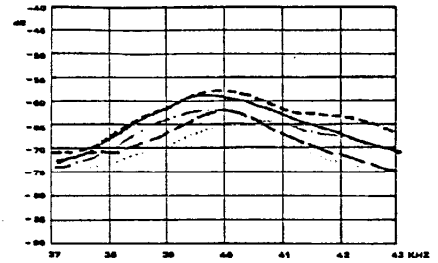
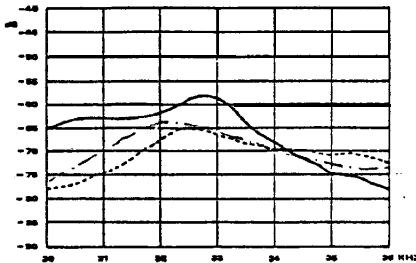
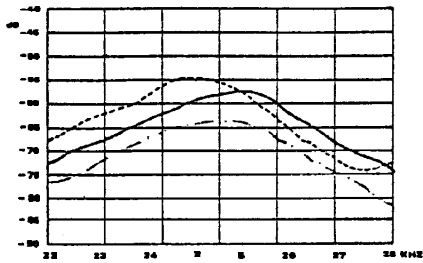

Transmitter: Sound Pressure Level

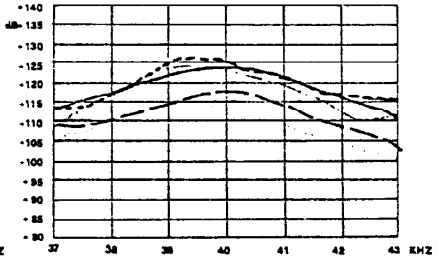
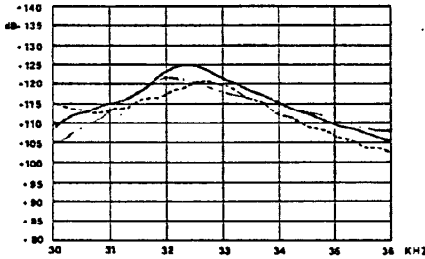
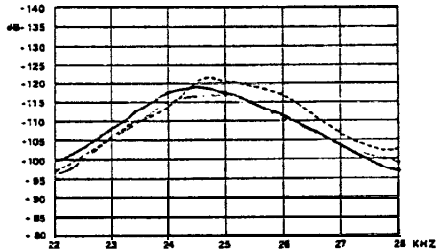

Impedance and Phase Angle

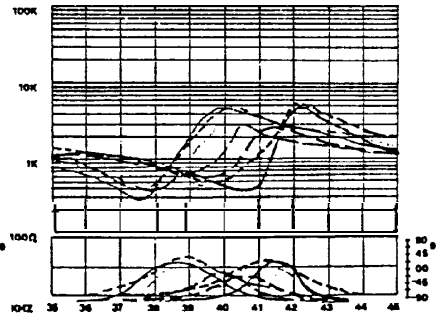
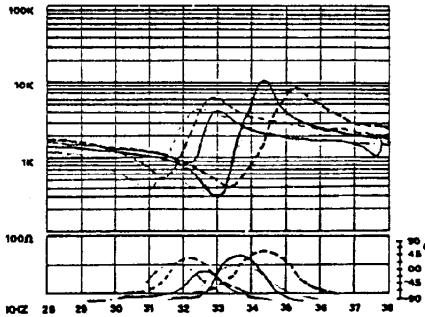
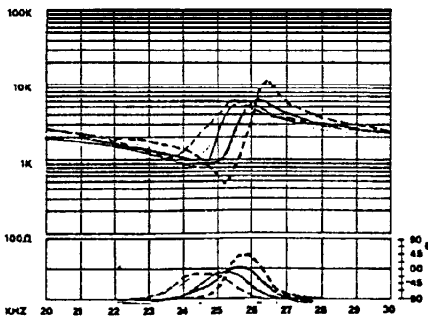

Directivity

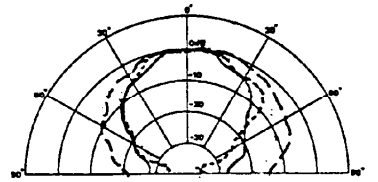
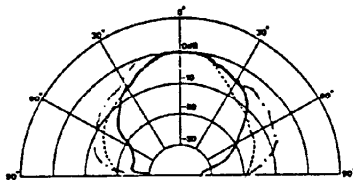
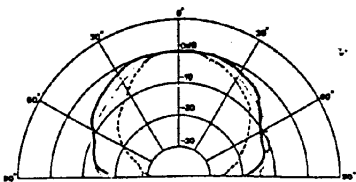

Open (S) Type Transducers

Characteristics Change Due to Load Resistance

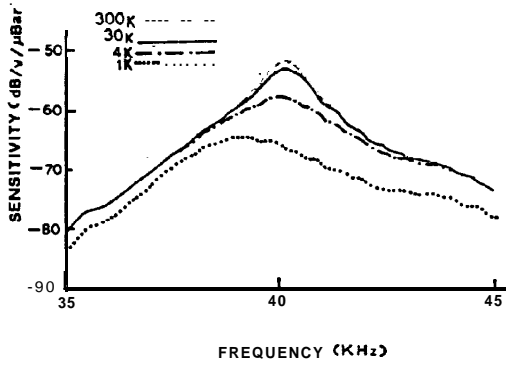

Characteristic Change Due to Input Voltage

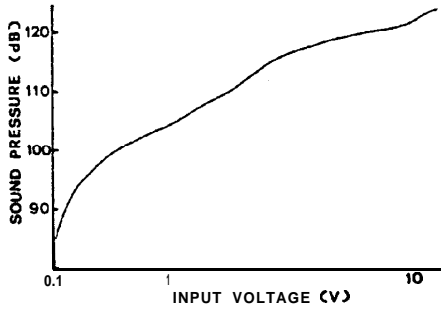

Frequency Shift Due to Input Voltage

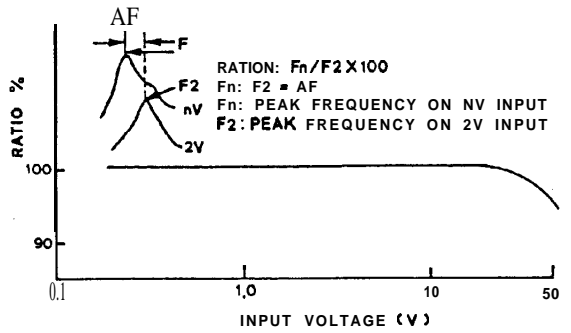

Humidity Characteristics And Shock Test

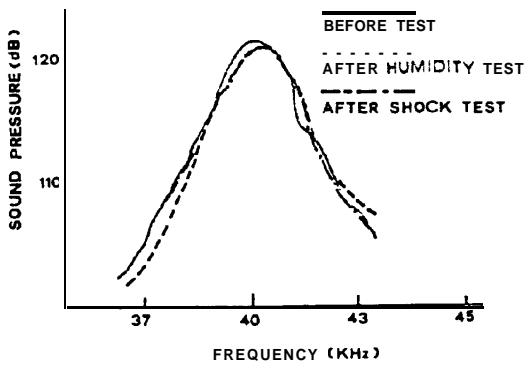

Temperature Characteristics

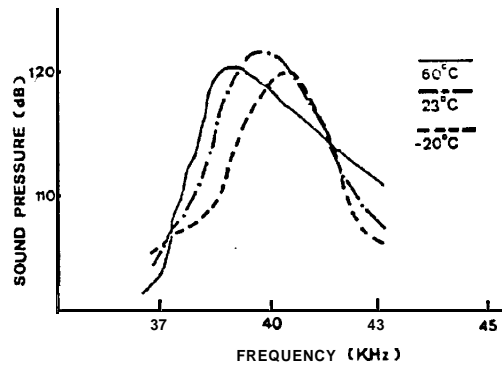

Durability

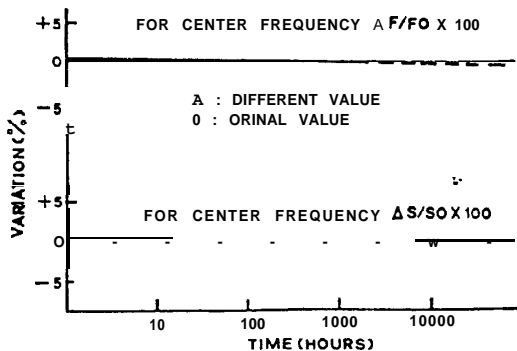

Temperature Cycle and Vibration Test

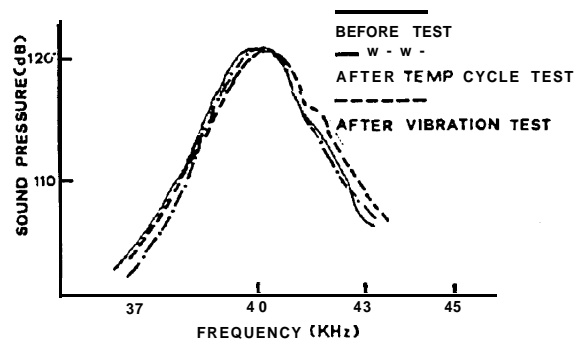

Ultraschallempfänger mit M A 4 0 L...

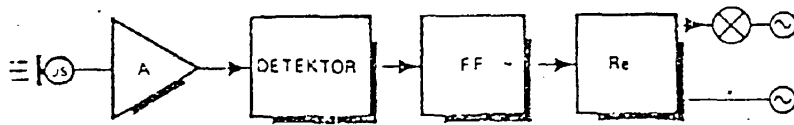

Dieser Empfänger bildet zusammen mit dem Ultraschallsender eine vielseitig verwendbare drahtlose Fernbedingung.

Das vom Wandler empfangene Signal wird zuerst von den in Kaskade-Schaltung betriebenen Transistoren T1 und T2 etwa 2000-fach verstärkt. T3 arbeitet als Detektor, T4 verstärkt das gleichgerichtete Signal. Dieses Signal triggert Flipflop T5/T6, so daß T7 über das Relais die angeschlossene Last ein- bzw. ausschaltet.

Um eine hauptstichtich' durch den Dopplereffekt verursachte Mehrfachtriggerung auszuschließen, bewirkt Kondensator C5 eine Mitkopplung zwischen T3 und T4. Diese beiden Transistoren verhalten sich daher ähnlich wie ein monostabiler Multivibrator. Eine optimale Betriebssicherheit läßt sich erreichen, wenn die Empfindlichkeit wie folgt eingestellt wird: Liegt der Schleifer von P1 an Masse, so zieht das Relais willkürlich an und fällt auch willkürlich wieder ab. P1 wird langsam so lange verstellt, bis das Relais seinen einmal eingennommenen Zustand bei-

behält. Damit ist die höchste Empfindlichkeit des Empfängers erreicht. Nach Einschalten des Senders muß sich das Relais vom Sender aus bedienen lassen. Das im Sender befindliche Poti P1 wird so eingestellt, daß eine möglichst große Entfernung überbrückt werden kann.

Steht Poti P1 des Senders in Mittelstellung, so muß die überbrückbare Entfernung mindestens 10 cm betragen. Nach richtiger Einstellung von P1 vergrößert sich der Abstand auf ungefähr 5 m. Bei noch größerer Reichweite nimmt man die Empfindlichkeit des Empfängers etwas zurück. Die Schaltung reagiert nämlich bei zu hoch eingestellter Empfindlichkeit auch auf Geräusche wie Händeklatschen, Papierknistern und ähnliches. Solche "Fehltriggerungen" kann man sich zum Beispiel für "Zaubertricksstücke" zu Nutze machen.

Als Wandler eignet sich jeder gebräuchliche Typ, jedoch sollte für Sender und Empfänger die gleiche Ausführung verwendet werden.

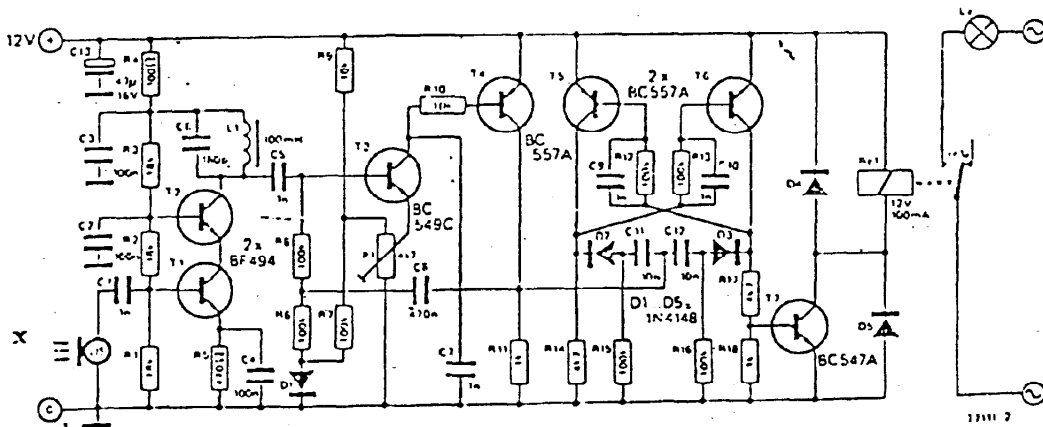

- x US-Mikrofon M A 4 0 L1R
- H A 4 0 L2R
- M A 4 0 L4

	8	Datum	Name	Maßstab	Bezeichnung
	7	Gezeichnet			Applikationsschaltung
	6	Geprüft			
	5	Werkstoff			
	4	Obertafel			
	3	Unterlagen		Nummer	

■ CIRCUIT EXAMPLE

The followings are application examples for MA40A5R/S.
Other types of sensors can be used by changing the constants.

1. Example of transmitting circuit

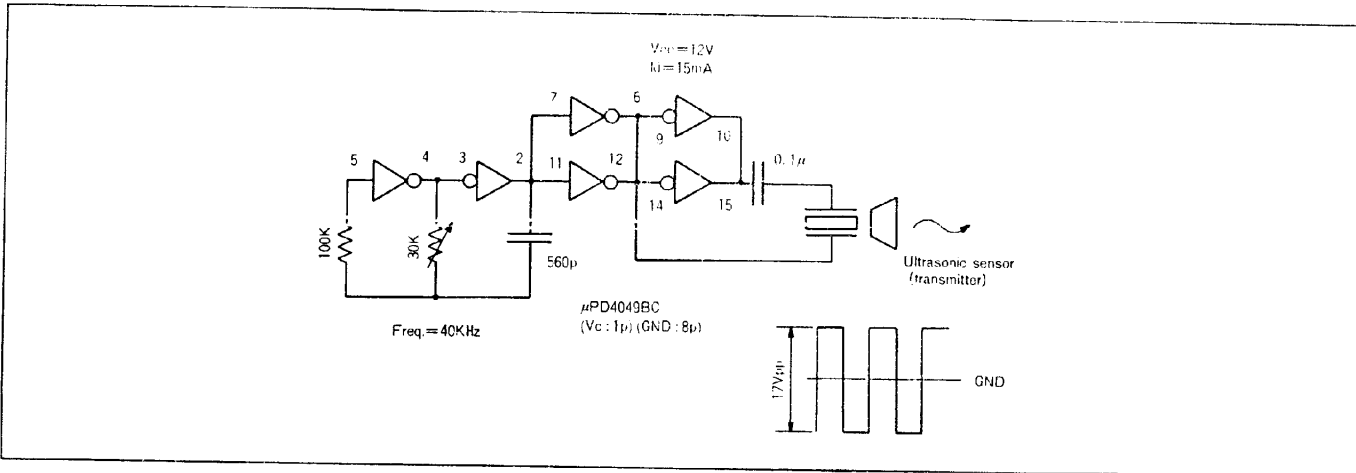

2. Example of pulse-transmitting circuit

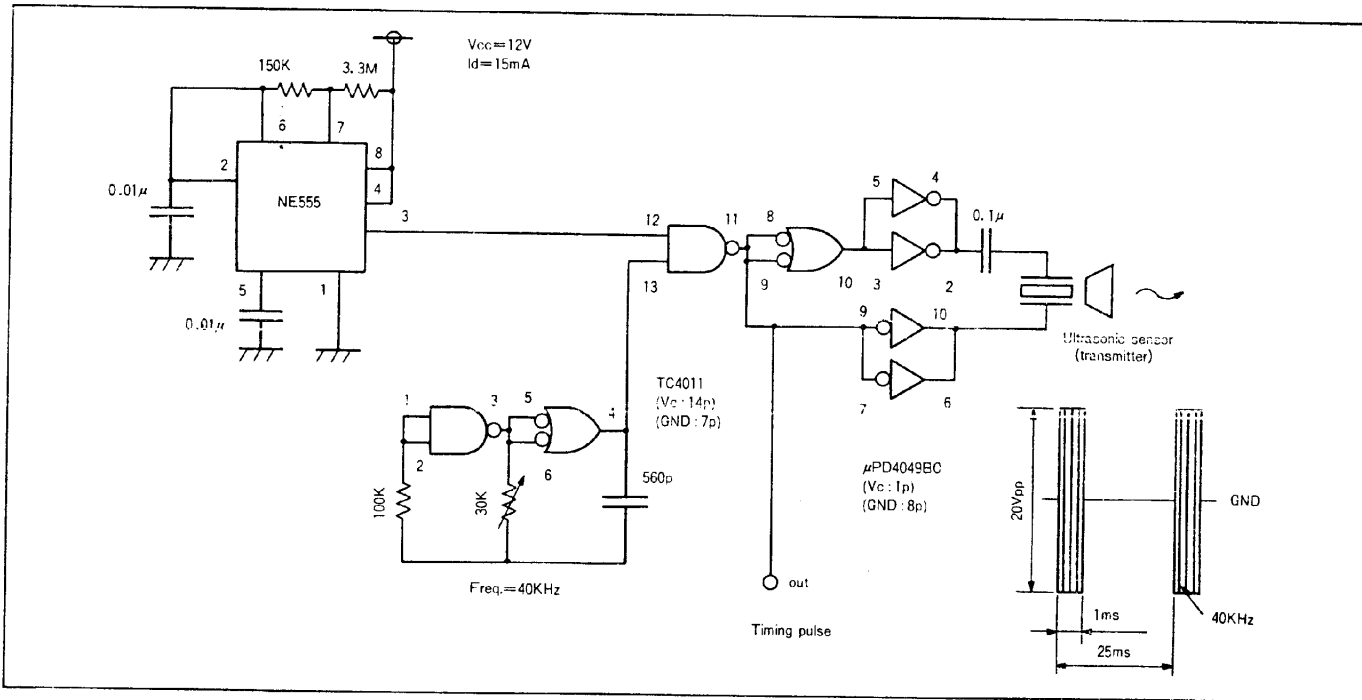

3. Example of receiving circuit

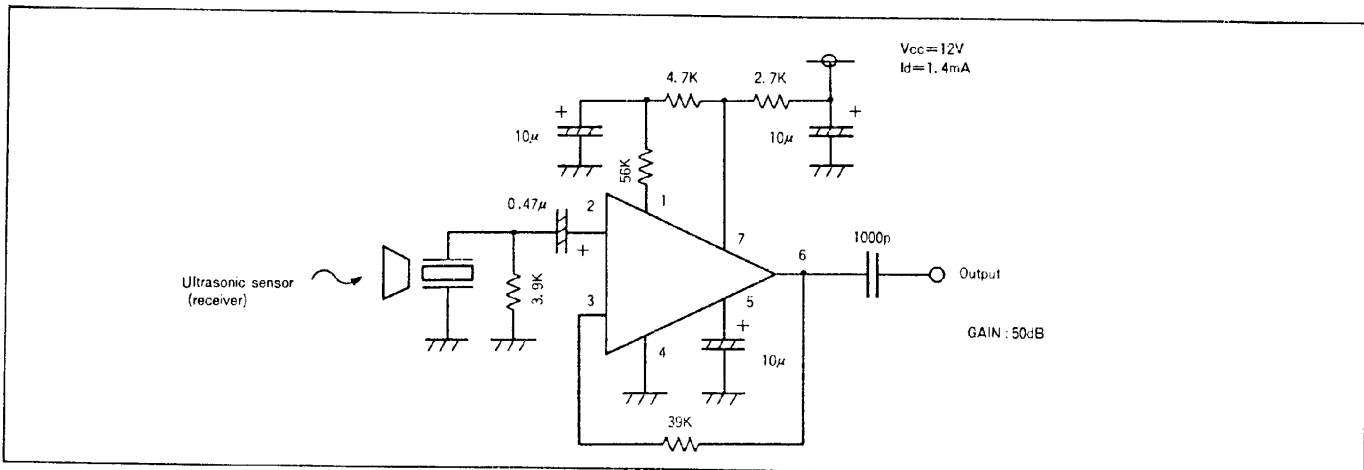

4. Principle diagram for distance measuring (pulse-reflecting method)

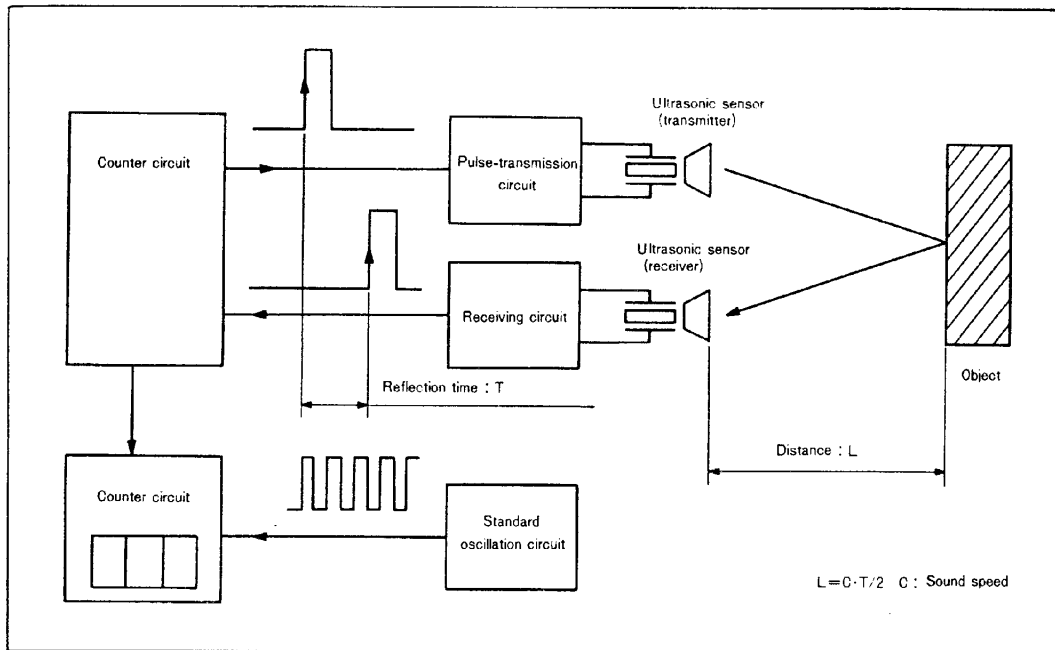

5. Application example for distance measuring

